

# Distributed contention-free traffic scheduling in IEEE 802.11 multimedia networks

Ravindra S. Ranasinghe Lachlan L.H. Andrew  
The ARC Special Research Centre for Ultra Broadband  
Information Networks (CUBIN),  
Dept. of Electrical and Electronic Engineering  
The University of Melbourne  
VIC. 3010, Australia  
{rran, lha}@ee.mu.oz.au

David Everitt  
Centre for Convergent Technologies (CCT)  
School of Biophysical Science and  
Electrical Engineering  
Swinburne University of Technology  
PO BOX 218 Hawthorn, VIC. 3122, Australia  
deveritt@swin.edu.au

*Abstract*— Wireless local area networks are a promising solution to support advanced data services in mobile environments. The IEEE 802.11 wireless LAN standard is emerging as a mature technology to support delay sensitive network services. In order to support these services the standard has proposed the use of a polling scheme; however, existing polling schemes require high communication overheads or suffer from unfairness. In this paper, we propose a distributed fair queueing algorithm, “distributed deficit round robin”, which is compatible with the 802.11 medium access control rules. Software simulation of this scheme shows that it can manage a heterogeneous mix of delay sensitive traffic.

*Key Words*— Round robin, Fair queueing, Medium access control, Polling, Scheduling, Wireless local area networks

## I. INTRODUCTION

Packet networks with advanced data services such as video, audio, voice and images have become a standard method of communication and people will soon be demanding these services in mobile environments. This has stimulated research into developing wireless multimedia networks to support a wide range of services with an acceptable level of performance.

Currently Wireless Local Area Networks (WLAN) technology is supported by two main standards: the IEEE 802.11 standard [26] and the High Performance Radio LAN (HIPERLAN) standard [23], developed by the European Telecommunication Standards Institute (ETSI). This work focuses on 802.11.

The 802.11 medium access control (MAC) protocol specifies a polling mechanism for delay sensitive data. However, the standard does not define the order of polling. In order to support multimedia services with diverse, sometimes contradictory qualities of service (QoS) requirements [7][2], an efficient packet scheduler is required. In particular, since services have varying bandwidth requirements, it must ensure a fair distribution of bandwidth. On the downlink, standard fair queueing (FQ) algorithms can be used, such as the Deficit Round Robin (DRR) algorithm described in [22]. Fair allocation of bandwidth to uplink traffic is more difficult as the details of packets awaiting transmission

are decentralized. Most of the proposed scheduling schemes for uplink traffic either suffer from unfairness or require a continuous exchange of information regarding the status of distributed queues. The 802.11 standard, however, does not support exchanging explicit information. In this paper, we examine a distributed FQ strategy, “Distributed Deficit Round Robin” (DDRR) [19][20], recently proposed by the authors.

We also present a complete scheduling scheme for 802.11 WLANs combining the DDRR and DRR strategies. The performance of this combined scheme and its interaction with asynchronous traffic are evaluated by software simulation. This algorithm can be used for both symmetric and asymmetric traffic and its efficiency can be improved by using the more data bit field of the MAC header for detecting empty queues.

This paper is organized as follows. The next section outlines the basics of 802.11 access control mechanisms and the important protocol features. Section III describes some existing schemes for polling list management, assessing their compatibility with the 802.11 MAC protocol. In Section IV we describe the Distributed Deficit Round Robin scheme. The combined scheduling scheme is detailed in Section V. Section VI presents the simulation model and the simulation results are presented in Section VII.

## II. IEEE 802.11 ACCESS PROTOCOLS

This section briefly summarises some of the features of the 802.11 MAC sublayer.

### A. Contention-based and Contention-free access

The IEEE 802.11 MAC layer supports two access modes, the distributed coordination function (DCF) and the point coordination function (PCF). These two modes provide contention-based and contention-free (CF) access to the physical medium. The physical transmission time is divided into cycles and each cycle is further divided into two time periods, a contention period (CP) and a contention-free period (CFP), which correspond to DCF and PCF respectively. This arrangement, shown in Figure 1, guarantees channel access to both asynchronous traffic and time-bounded traffic in each cycle.

### B. Distributed Coordination Function

A station wishing to transmit a data packet under DCF must sense the medium before starting the transmission. If the medium is busy, the transmission is deferred: the station backs off for a random time interval uniformly distributed in a prespecified range. If the station senses an idle channel, it makes sure that the channel is idle for a minimum time period (DIFS) and then starts the transmission. This is shown in Figure 2, taken from [1].

### C. Point Coordination Function:

PCF mode is controlled by a Point Coordinator (PC), which operates from a centralized “access point”, analogous to the base station in a cellular network. The PC transmits a beacon frame (**B** in Figure 1) to announce the CFP to all stations. This puts the stations in a hold state in which they cannot transmit in DCF mode. The PC then polls the stations in the polling list according to a predetermined strategy. Once a station is polled, it has the right to transmit a single frame while all the other stations remain idle. Stations with no time-bounded packets waiting for transmission will respond with a CF-NULL frame. The CFP Repetition interval (Figure 1) describes the rate at which the CF cycle occurs. The length of the CF period is bounded above by `CFP_Max_Duration`.

### D. The Polling List

Stations having delay sensitive data to transmit will compete for the channel together with asynchronous stations, in order to be admitted into the polling list. Once the PC receives an “association”, it inserts the station into the polling list. PC polls the stations in polling list during the CF transmission period.

### E. The “More Data” bit

The 802.11 MAC header contains a single bit “more data” field. In each poll response sent back to the PC, a station sets the “more data” bit if and only if it has packets waiting to be sent. This can be used to reduce the polling of empty queues.

### F. Transmission acknowledgements

Each MAC protocol data unit (MPDU) transmitted under either access mode must be acknowledged by the recipient at the MAC layer. In order to save bandwidth, the standard allows this acknowledgement to be combined with one of the CF-Poll, Data or CF-End frames. Details of these two access mechanisms can be found in [1][8][25][26].

## III. CONTENTION FREE ACCESS MANAGEMENT

As proposed in the 802.11 standard, the PCF access mode uses a polling scheme to distribute the bandwidth during the contention free (CF) period. This section

discusses the need for a FQ strategy and reviews some of the existing centralized and distributed FQ schemes, identifying the problems for implementing them on 802.11.

### A. Traffic stream management in the downlink

The scheduler running at the PC may use non-limited scheduling policies such as first-come first-serve (FCFS) or deadline-ordered scheduling disciplines [11] to handle the downlink traffic. As we consider networks carrying a heterogeneous mix of delay sensitive traffic, these disciplines may cause unfairness for some traffic flows. Therefore, service disciplines which can limit the amount of traffic transmitted by each flow are more attractive than non-limited service disciplines.

The primary goal of FQ [10][13][24][27] is to distribute the bandwidth equally among all competing sessions. In FQ, users with moderate bandwidth requirement are not penalized because of excessive demands of others. FQ has been enhanced to allow for weighted assignment of bandwidth [3][4]. The round robin service discipline gives equal bandwidth to all the queues if the average packet size over the duration of a flow is the same for all flows [18]. However, when the lengths of packets are not the same and/or the service shares assigned to the sessions are not equal, the definition of fair queueing and the right order of providing service to the sessions becomes a more subtle matter [13]. This is the case in multimedia networks since for example, video packets will typically be larger than voice packets.

A simple FQ algorithm called Deficit Round Robin (DRR) [22] was proposed by Shreedhar *et al.*. In DRR, each queue,  $i$ , waiting for service has a *deficit counter* ( $DC_i$ ). At the start of each round,  $DC_i$  is incremented by a specific service share, or *quantum*,  $Q$ . If  $DC_i$  is less than the length of the next packet, then the scheduler moves to queue  $i+1$  without servicing queue  $i$ . Otherwise, it sends the packet and reduces  $DC_i$  by the packet length. That means that queue  $i$  has to wait until enough credit is accumulated on  $DC_i$  before receiving the service. The  $DC_i$  is reset to 0 whenever the  $i^{\text{th}}$  queue becomes empty. Clearly, the DRR scheduler requires knowledge of the length of the next packet.

### B. Traffic stream management in uplink

Unlike downlink flows, the uplink traffic flows in wireless networks are decentralized (localized to the stations) and the scheduler has limited information about these queues. Therefore, most FQ schemes cannot be directly used on the uplink.

The polling schemes investigated in [5][6][15] for multiplexing heterogeneous traffic in WLANs make no attempt to ensure fairness. Schemes based on peak rate reservation and fixed frame length, like R-Aloha [9] and PRMA [14], may result in under-utilization of network

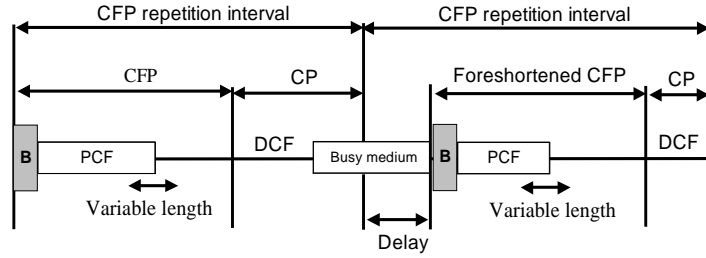

Figure 1. CFP/CP alternation within the contention-free repetition interval

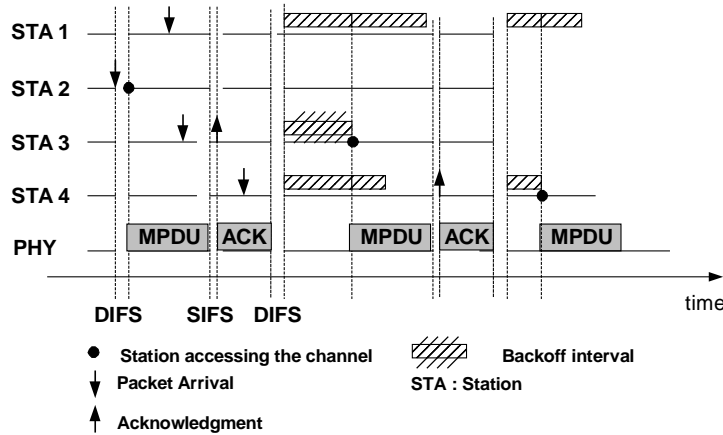

Figure 2. BASIC ACCESS MECHANISM OF 802.11

resources if the peak-to-average ratios are high. Distributed self-clock fair queueing [16], Fully Gated Limited (FGL) and non-uniform FGL polling schemes [17] are some of the fair queueing schemes proposed for managing distributed uplink traffic.

Implementation of these FQ schemes requires a continuous exchange of explicit information regarding the distributed queues. As the proposed 802.11 MAC protocol does not support exchanging additional packets either at the beginning of each CF period or during the CF period, the schemes described above cannot be used at the PC. One may think of using the standard round robin scheme which would work with the 802.11 MAC protocol for polling list management. However, round robin is unfair if traffic streams have different average packet lengths. This paper mainly focuses on a scheduler based on a distributed FQ scheme for uplink traffic in an 802.11 WLAN carrying a heterogeneous mix of delay sensitive traffic. The scheme is a distributed form of the DRR scheme and is described in the following section.

#### IV. DISTRIBUTED DEFICIT ROUND ROBIN

The Distributed Deficit Round Robin (DDRR) scheme [19][20] is based closely on DRR. Each admitted connection  $i$  is again assigned a Deficit Counter,  $DC_i'$ ,

which is incremented by the quantum,  $Q$ , in a round robin fashion. However, as soon as  $DC_i'$  becomes positive, the scheduler allows the  $i^{\text{th}}$  queue to send one packet. After that,  $DC_i'$  is decremented by  $L_i$ , where  $L_i$  includes both the length of the transmitted packet and the polling and transmission overhead. This is repeated as long as  $DC_i'$  remains positive. If  $DC_i' \leq 0$ , then the scheduler does not poll the  $i^{\text{th}}$  queue, instead moving to the next entry in the polling list. Therefore servicing the  $i^{\text{th}}$  queue is backlogged to the next cycle.

As in DRR,  $DC_i'$  is reset to 0 whenever the  $i^{\text{th}}$  queue becomes empty. DDRR can sense that a queue is empty when it receives an empty response to its poll. This unnecessary poll can be eliminated if we assume that the packet header has a single "more data" bit field, such as provided in 802.11.

Figure 3 illustrates the operation of the DDRR scheduler with four queues. The scheduler goes through the complete polling list in round robin fashion (1,2,3,4,1,2...) checking the deficit counters. The scheduler increments the value of the corresponding  $DC_i'$  by the quantum,  $Q$ , before it checks whether  $DC_i' > 0$ . The crosshatched areas bounded by the dark lines represent the current levels of  $DC_i'$  of each station, after incrementing by  $Q$ . After adding  $Q$  to  $DC_2'$ , it is still negative. The scheduler

thus bypasses station 2 and moves to station 3. After adding  $Q$  to  $DC_3'$ ,  $DC_3' > 0$ , and hence the scheduler polls station 3, allowing it to transmit the next packet of length  $X$ . Then  $DC_3'$  is decremented by  $X$ . After that,  $DC_3' < 0$ , and the scheduler moves to station 4.

Note that in DRRR, a packet is transmitted first and then the consumed bandwidth is “paid off”. In contrast, under DRR a station must save enough credit prior to the packet transmission. This trivial change allows the scheduling to be performed on the distributed queue. The pseudo-code for the DRRR algorithm is given in the Appendix.

Figure 4 illustrates how the transmission of packets in the  $i^{\text{th}}$  queue is scheduled by DRRR. The rectangles on the left represent the length of the packets waiting for service at the station and the rectangles on the right represent the corresponding deficit counter maintained by the PC. In the first round, the  $i^{\text{th}}$  queue transmits the first two frames in the queue. After that  $DC_i'$  goes negative and the  $i^{\text{th}}$  queue is not permitted to transmit during the second round. By the third round, the  $i^{\text{th}}$  queue has “paid off” the consumed bandwidth and is allowed to continue its transmission.

#### A. Analytical results

Fairness can be quantified by  $FM(t_1, t_2)$ , which measures the maximum difference between the normalized service received by two backlogged sessions over the interval  $(t_1, t_2)$  in which both sessions are continuously backlogged. The following theorem shows that the fairness bounds for DRRR are the same as those of DRR (i.e. Theorem 3 [22]). In order to prove this result we make use of the following analogous of Lemmas 1 and 2 of [22].

*Lemma 1:* Each time the DRRR scheduler finishes processing one station,  $-L_{\max} < DC_i' \leq 0$ , for each  $i$ , where  $-L_{\max}$  is the maximum packet size.

*Proof:* As  $DC_i'$  is unaffected by the processing of stations other than station  $i$ , we need only consider the case of the scheduler finishing processing station  $i$ .

To see that  $DC_i' > -L_{\max}$ , we argue as follows. Let  $X$  be the last packet transmitted by the  $i^{\text{th}}$  flow before finishing processing station  $i$ , and let  $L(X)$  denotes the length of the packet  $X$ . Note that  $L(X) \leq L_{\max}$ . If no packet has ever been transmitted,  $DC_i' \geq 0 > -L_{\max}$ , since  $DC_i'$  is initialised to 0. In order to allow the  $i^{\text{th}}$  queue to transmit packet  $X$ ,  $DC_i'$  must have been positive after transmitting all the packets before packet  $X$ . That is,

$$DC_i' = \varepsilon$$

for some  $\varepsilon > 0$ . The value of  $DC_i'$  before the scheduler moves to the  $(i+1)^{\text{st}}$  entry thus satisfies

$$DC_i' = \varepsilon - L(X) > -L_{\max}.$$

It remains to show that  $DC_i' \leq L_{\max}$ . The DRRR scheduler only leaves queue  $i$  when either (a) queue  $i$  has exhausted its quota, indicated by  $DC_i' \leq 0$  or (b) the remote queue is empty, indicated by an empty packet or by

a more data bit being reset. In the latter case,  $DC_i'$  is set to 0. Thus in either case  $DC_i' \leq 0$ . Therefore  $-L_{\max} < DC_i' \leq 0$  for each  $i$  when the DRRR scheduler finishes processing any station, as required.  $\square$

*Lemma 2:* Let queue  $i$  be backlogged during the time interval  $(t_1, t_2)$  of any execution. Let  $m$  be the number of round robin service opportunities received by the queue  $i$  during the interval  $(t_1, t_2)$ . Then

$$mQ_i - L_{\max} \leq \text{sent}_i(t_1, t_2) \leq mQ_i + L_{\max},$$

where  $\text{sent}_i(t_1, t_2)$  is the number of bytes transmitted by the  $i^{\text{th}}$  backlogged session during the interval  $(t_1, t_2)$  and  $Q_i$  is the quantum assigned on  $i^{\text{th}}$  flow.

The proof of this lemma is analogous to the proof of Lemma 2 in [22].

*Theorem 3:* For interval  $(t_1, t_2)$  in any execution of the DRRR algorithm

$$FM(t_1, t_2) \leq 2L_{\max} + Q$$

where  $Q = \min_i(Q)$  and

$$FM(t_1, t_2) = \max_{i, j \in B} \left( \frac{\text{sent}_i(t_1, t_2)}{f_i} - \frac{\text{sent}_j(t_1, t_2)}{f_j} \right)$$

where  $B$  is the set of backlogged sessions in the interval  $(t_1, t_2)$  and the quantity  $f_i$  expresses the ideal share to be used by flow  $i$

Once again, the proof is analogous to Theorem 3 in [22].

#### V. COMBINED UPLINK AND DOWNLINK SCHEDULING

The scheduler must distribute the bandwidth fairly on both the uplink and the downlink. For each two-way session, the scheduler combining the DRRR and the DRR disciplines maintains two independent counters: one to control the uplink and one for the downlink. These counters are active only when the corresponding flow has joined the polling list. That means that it is possible for the downlink to be active while the corresponding uplink flow is inactive or vice versa.

If the scheduler can send poll requests to the stations combined with downlink data packets, it is possible to reduce the transmission overhead and hence to increase the overall transmission efficiency. The 802.11 standard supports this form of piggybacking.

This combined strategy is as follows. The  $i^{\text{th}}$  flow uses two deficit counters,  $DC_i'$  for the uplink and  $DC_i$  for the downlink, with the same quantum  $Q_i$ . Let  $L_i$  denote the length of the packet at the head of the  $i^{\text{th}}$  downlink queue including the transmission overhead. When the scheduler starts processing the  $i^{\text{th}}$  queue, after incrementing  $DC_i'$  and  $DC_i$ , there are four possibilities:

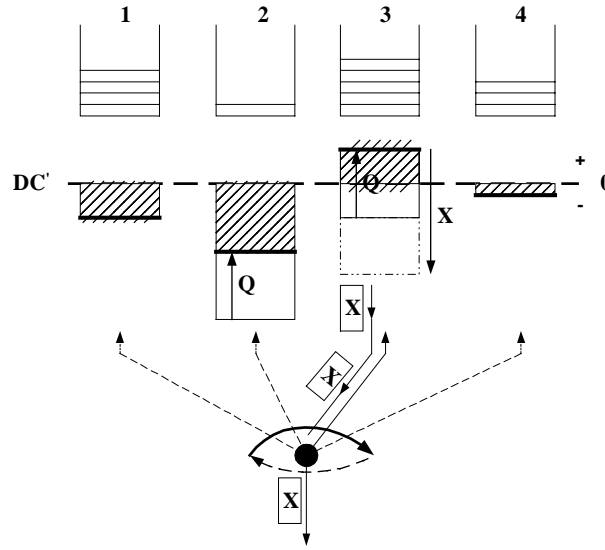

Fig. 3. DRR servicing policy

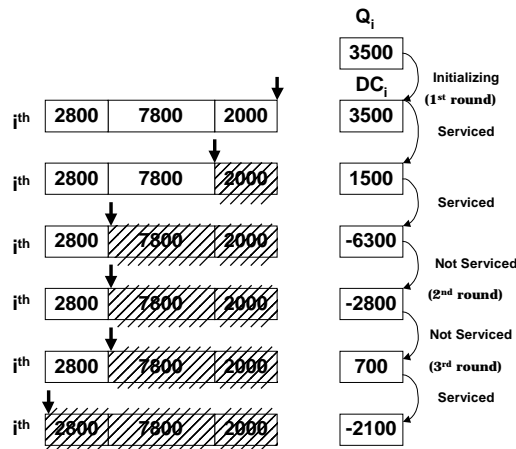

Fig. 4. Distributed Deficit Round-Robin scheme

1.  $DC_i' > 0, DC_i \leq L_i$ : A poll request is sent
2.  $DC_i' \leq 0, DC_i > L_i$ : The downlink packet is sent.
3.  $DC_i' > 0, DC_i > L_i$ : The packet is sent with a piggybacked poll request.
4.  $DC_i' \leq 0, DC_i \leq L_i$ : The scheduler moves to the next station in round robin order.

The deficit counters are then updated according to the DRR and DRR rules. The DRR scheduler uses the “more data” feedback bit as described in Section IV to reduce null frame transmissions. Moreover, the proposed scheduler deactivates these empty queues for the rest of the CFP. The scheduler continues to send polls to the stations until the expiration of  $CFP\_Max\_Duration$  or all the entries in the polling list become inactive, whichever

occurs first. Thus the advantages of using “more data” bit is two fold: it can effectively use to reduce the chances of sending poll requests to empty uplink streams and it can also be used to detect the level of delay sensitive traffic. The scheduler is thus adaptive to delay sensitive traffic load.

Since there is no extra bandwidth required for a piggybacked poll request as suggested in the standard, the efficiency of the combined strategy can be further improved by sending a piggybacked poll request even when  $DC_i' = 0$ . This aspect has not been investigated in this work.

## VI. SIMULATION DESCRIPTION

A WLAN carrying a mixture of real-time traffic and non-real-time asynchronous traffic was simulated with DRRR. This will be compared with the standard round robin (RR). When using RR, the more data bit was used in the same way as it was with DRRR.

### A. Network system architecture

A single cell infrastructure WLAN was simulated with voice and video terminals communicating with a backbone network. There were also 10 asynchronous data terminals transmitting data packets among themselves, but not to or from the backbone network. This is illustrated in Figure 5.

### B. Traffic models

The services in this experiment represent two classes of real-time traffic: an interactive low bandwidth class and a non-interactive high bandwidth class. Voice traffic was used to represent the interactive low bandwidth class and MPEG video traffic to represent non-interactive high bandwidth class. Note that the delay requirement of interactive traffic is more stringent than the delay requirement of non-interactive traffic. Even though we use a single traffic stream to represent each class, the assumption is that multiple streams would have comparable delay requirements had a source with multiple streams been used. If this is not the case, the node may use a method such as class base queueing (CBQ) [12] to distribute bandwidth among the competing streams.

*Voice traffic:* The voice source is modeled as Markov ON/OFF process with a talking state or a silent state. When the source is in the talking state it periodically generates fixed size voice packets. The CF repetition period was set to the inter-arrival time of these voice packets. Voice connections are full-duplex transmitting data in both the uplink and the downlink directions.

*Video traffic:* The video traffic sources generate frames at a constant rate. The lengths of the video frames were taken from the real traffic traces used in [21]. The video frames can be larger than the maximum MPDU length. These packets are segmented and sent to the MAC layer as a packet burst. Video connections are also full-duplex. When a video connection is set up, two randomly selected MPEG traces are attached to the uplink and downlink.

*Data traffic:* Asynchronous traffic transmitted during the contention period may delay the start time of CF cycles, and was included in our model. The data traffic was generated by 10 stations and had a Poisson arrival process and negative exponential packet lengths.

### C. System parameters

We used the default values given in [26] for all the DCF and PCF related attributes. Tables I and II show important parameters of the simulation set up. The contention free

repetition interval (20 ms) is partitioned into a contention-free period and a contention-based period. The boundary was variable but the contention-based period was at least 5 ms in each cycle to allow a maximum size MPDU to be transmitted.

## VII. SIMULATION RESULTS

The network was subjected to three different types of traffic generated by data, voice and video terminals. Each simulation run consists of 175,000 CF cycles after a warm-up period of 5,000 cycles. Several tests were performed by varying both the contention free and the contention-based traffic loads to examine their interaction. We also found the number of full duplex voice and video connections that can be supported by a 10 Mbps 802.11 WLAN satisfying the following QoS requirements: This paper looks at the problem of maximising the number of connections while satisfying individual QoS requirements.

- 99% of the interactive (voice) MPDUs must be transmitted with MPDU delay less than 32 ms
- 99% of the non-interactive (video) MPDUs must be transmitted with MPDU delay less than 100 ms.

The “delay” refers to the access delay, which is the sum the MAC delay and the queueing delay. Note that the expired packets of all real-time sessions are discarded. Then contention-based traffic was varied after fixing the CF traffic for those identified values to maximise the overall network throughput.

### A. Effect of “more data” bit on CF cycle length

Figures 6-8 show the contention free cycle length for three values of delay sensitive load ( $G_{CFP}$ ) shown in Table III. The DRRR scheduler clearly detects the level of the contention free traffic and terminates the CF cycle as early as possible freeing the bandwidth for contention traffic.

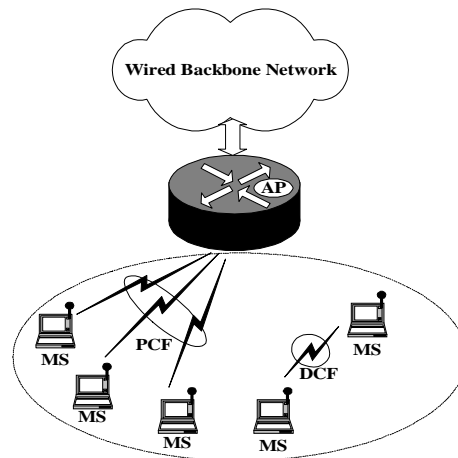

Fig. 5. Network architecture of interest

### B. Effect of real time traffic on asynchronous traffic delay

The time bounded traffic load offered to the network affects the asynchronous traffic transmission as shown in Figure 9. With increasing CF load, the length of the contention-free transmission period increased, reducing the time available for contention-based transmission. Therefore packet latency increases for a given level of asynchronous traffic. As would be expected, the latency also increases for increasing contention-based load. Note that for a given total traffic, the contention-based delay increases as the proportion of CF traffic decreases, showing that PCF is more efficient than PCF.

### C. CF cycle length, data traffic and voice MPDU loss

As mentioned earlier, voice packets are discarded if their waiting time exceeds 32 ms. The percentage voice MPDU loss will increase as the contention free load increases due to increasing queue delay, as shown in Figure 10. It also increases with increasing asynchronous load. This is because voice stations connect to the PC for each talk burst and there is higher probability that the association frames experience collisions.

Figure 11 shows the intensity of the voice MPDU loss for different combinations of contention-based and contention free loads. In this diagram, darker squares correspond to lower voice MPDU loss.

### D. IEEE 802.11 Network capacity under DRR and RR

Figure 12 shows the number of voice and video sessions that can be supported by the network satisfying the specified QoS measures under DRR and RR. The term “session” refers to a full duplex connection in this context. When the offered network traffic is homogenous (points A and B in Figure 12), DRR and RR perform similarly. However, for heterogeneous traffic, the average packet length varies between flows and RR becomes unfair. DRR gives higher priority to the smaller but more frequent voice packets and thus increases the capacity. This confirms that DRR scheduling outperforms RR for IEEE 802.11 wireless networks with a heterogeneous packet mix.

### E. CF traffic throughput

Figure 13 shows how overall delay sensitive throughput varies with an increasing number of non-interactive (video) sessions when the network is presented with a mixture of interactive (voice) and video traffic subjected to the specified QoS constraints. This graph shows that throughput increases with increasing video traffic. This is because the delay requirement of the video (non-interactive) traffic is laxer than that of voice (interactive) traffic. Note that the throughput is calculated as a fraction of total channel capacity. Therefore cannot approach 100% because of the intrinsic polling and transmission overheads.

TABLE I. MAC AND PHY CHANNEL CONFIGURING ATTRIBUTES

Attributes	Value
PHY medium capacity	10 Mbps
Number of Data stations	10
CFP repetition interval	20 ms
CFP_Max_Duration	15 ms

TABLE II. ATTRIBUTES OF VOICE AND VIDEO SOURCES

Attributes	Voice	Video
Average Source Rate (when active)	64 Kbps	0.4 Mbps
Frame Duration	20 ms	40 ms
Maximum Delay	32 ms	100 ms
Mean ON Duration	1.0 sec	N/A
Mean OFF Duration	1.35 sec	N/A
Quantum size	2208 bits	16524 bits

### F. Total throughput

Figure 14 shows the total channel utilization by both CF traffic and contention-based traffic. The total channel utilization is obtained by optimizing the contention-based traffic for each combination of contention free traffic satisfying the QoS requirements of both voice and video, and then normalizing the sum of the throughputs of both contention-based and contention free traffic with respect to the total channel capacity. This shows that the PCF-DCF access mechanism proposed in the IEEE 802.11 standard achieves maximum of 69% channel utilization if DRR/DRR scheme is employed to control the polling list management.

## VIII. CONCLUSIONS

This paper has presented a fair queueing scheduler to control both uplink and downlink traffic in wireless LANs. The proposed scheme was evaluated by the software simulation of an IEEE 802.11 network. We examined the impact of the scheme on network capacity and how the scheme interacts with contention-based traffic.

It was shown that terminating the CF cycle when no stations have further data to transmit can increase the amount of bandwidth available for contention-based traffic and increase the overall network utilization.

It was also shown that asynchronous traffic can increase the delay of delay sensitive traffic, by colliding with the “control frames” used for establishing connections. This could be avoided by using alternative mechanisms to handle these control frames. Under the conditions studied, the 802.11 wireless LAN achieved between 50% and 69% utilization.

This demonstrates that the IEEE 802.11 MAC protocol point coordination function (PCF) can carry heterogeneous delay sensitive traffic and can coexist with the contention based distributed coordination function.

## References

- [1] G. Anastasi, L. Lenzi, E. Mingozzi, "MAC protocols for wideband wireless access: Evolution towards wireless ATM," *IEEE Personal Commun.*, Oct. 1998, pp. 53-64.
- [2] H. Armbruster, K. Wimmer, "Broadband multimedia applications using ATM networks: High performance computing, high capacity storage, and high speed communication," *IEEE J. Sel. Areas Commun.*, Dec. 1992, Vol. 10, no. 9, pp 1382-1396.
- [3] J.C.R. Bennett, H. Zhang, "Hierarchical packet fair queueing algorithms," *Proc. SIGCOMM'96*, Aug. 1996, pp. 143-56.
- [4] J.C.R. Bennett, H. Zhang, "WF<sup>2</sup>Q: Worst-case fair weighted fair queueing," *Proc. INFOCOM'96*, Mar. 1996, pp. 120-27.
- [5] K.C. Chen, C. H. Lee, "Group randomly addressed polling for multicell wireless data networks," *ICC' 92*, 1992, pp. 1025-31.
- [6] K.C. Chen, C. H. Lee, "RAP – A novel medium access control protocol for wireless data networks," *Proc IEEE Globecom '93*, 1993, Vol. 3, pp. 1713-17.
- [7] D.D Clark, S. Shenker, L. Zhang, "Supporting real-time applications in an integrated services packet network: Architecture and mechanism," *Proc. ACM SIGCOMM'92*, August 1992, pp. 14-26.
- [8] B.P. Crow, I. Widjaja, J.G. Kim, P. Sakai, "Investigation of the IEEE 802.11 medium access control (MAC) sublayer functions," *Proc. INFOCOM 97*, Apr. 1997, Kobe, Japan, pp.126-33.
- [9] W. Crowther, R. Rettberg, D. Walden, S. Ornstein, F. Heart, "A system for broadcast communication : Reservation – ALOHA," *Proc. 6<sup>th</sup> Hawaii Int. Conf. Sys. Sci.*, 1973, pp. 596-603.
- [10] A. Demers, S. Keshav, S. Shenker, "Analysis and simulation of a fair queueing algorithm," *Proc. SIGCOMM 89*, Sept. 1989, Vol. 19, No. 4, pp.1-12.
- [11] N.R. Figueira, J. Pasquale, "A schedulability condition for deadline-ordered service disciplines," *IEEE/ACM Trans. Networking*, April 1997, Vol.5 No. 2, pp.232-44.
- [12] S. Floyd, V. Jacobson, "Link sharing and resource management models for packet networks," *IEEE/ACM Trans. Networking*, August 1995, Vol. 3, no. 4, pp. 365-86.
- [13] S.J. Golestani, "A self-clocked fair queueing scheme for broadband applications," *Proc. INFOCOM '94*, 1994, pp. 636-46.
- [14] D.J. Goodman, S.X. Wei, "Efficiency of packet reservation multiple access," *IEEE Trans. Vehic. Tech.*, Feb. 1991, Vol. 40, No. 1, pp. 170-6.
- [15] A. Hoffman, R. J. Haines, A.H. Aghvami, "Performance analysis of a token based MAC protocol with asymmetric polling strategy ("TOPO") for indoor radio local area networks under channel outage conditions," *ICC' 94*, 1994, pp. 1306-11.
- [16] R. Kautz, A. Leon-Garcia, "A distributed self-clocked queueing architecture for wireless ATM networks," *Proc PIMRC'97*, 1997, Vol. 1, pp. 189-93.
- [17] N. Movahhedinia, G. Stamatelos, H.M. Hafez, "Polling-based multiple access for indoor broadband wireless systems", *Proc. PIMRC 95*, 1995, Vol. 3, pp. 1052-6.
- [18] J. Nagle, "On packet switches with infinite storage," *IEEE Trans. Commun.*, Apr. 1987, vol. COM-35, no 4.
- [19] R.S. Ranasinghe, L.L.H. Andrew, D. Everitt, "Impact of polling strategy on capacity of 802.11 based wireless multimedia LANs," *Proc. IEEE ICON'99*, Sep. 1999, pp 96-103
- [20] R.S. Ranasinghe, D. Everitt, L.L.H. Andrew, "Fair queueing scheduler for IEEE 802.11 based wireless multimedia networks," *Multiaccess, Mobility and Teletraffic in Wireless Communications*, Vol. 4, E. Biglieri, L. Fratta and B. Jabbari (eds), Kluwer Academic Publishers, 1999, pp. 241-51.
- [21] O. Rose, "Statistical properties of MPEG video traffic and their impact on traffic modeling in ATM systems," *Proc. 20<sup>th</sup> Annual Conf. Local Comp. Network*, Minneapolis, CA, Oct. 1995.
- [22] M. Shreedhar, G. Varghese, "Efficient fair queueing using deficit round robin," *IEEE/ACM Trans. Networking*, 1996, Vol. 4 No. 3, pp. 375-85.
- [23] ETSI TC-RES, "Radio Equipment and Systems (RES); High Performance Radio Local Area Networks (HIPERLAN); Type 1; Functional Specification, Technical correction," Dec. 1996
- [24] A. Varma, D. Stiliadis, "Hardware implementation of fair queueing algorithms for asynchronous transfer mode networks," *IEEE Commun. Mag.*, Dec. 1997, Vol. 35, pp. 54-68.
- [25] M.A. Visser, M. E. Zarki, "Voice and data transmission over an 802.11 wireless network", *Proc. PIMRC 95*, Sep. 1995, Toronto, Canada, pp. 648-52.
- [26] P802.11, Wireless medium access control (MAC) and physical layer (PHY) working group, IEEE 802.11 draft standard, "Wireless medium access control (MAC) and physical layer (PHY) specifications," IEEE Stds. Dept., Jul. 1996, D5.
- [27] L. Zhang, "VirtualClock: A new traffic control algorithm for packet switching networks," *IEEE/ACM Trans. Comp. Sys.*, May 1991, Vol. 9, pp. 101-24.

TABLE. III. LOW, MEDIUM AND HIGH LEVELS OF CONTENTION FREE LOAD

	Figure 6	Figure 7	Figure 8
Number of voice sources	10	10	10
Number of video sources	0	3	6
Total normalized delay sensitive traffic load, ( $G_{CFP}$ )	0.0524	0.2829	0.5295

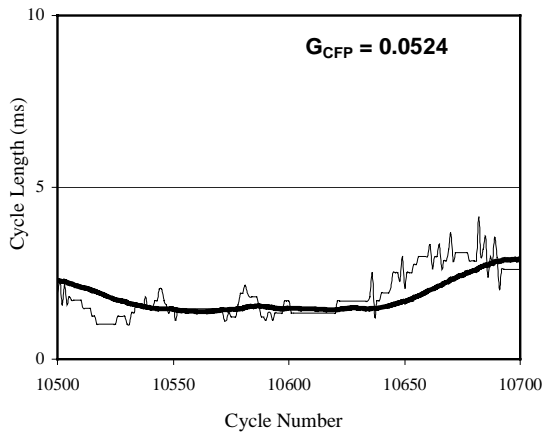

Fig. 6. Low level of delay sensitive load

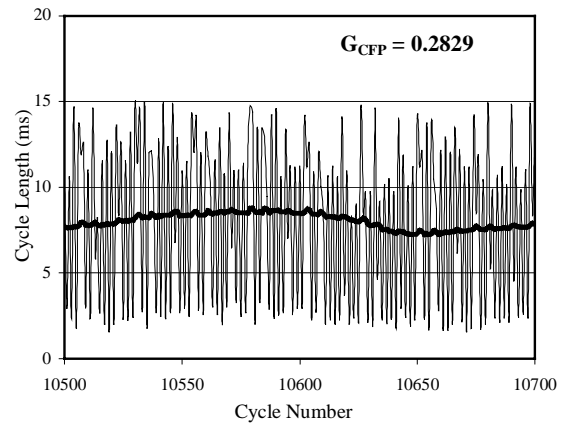

Fig. 7. Medium level of delay sensitive load

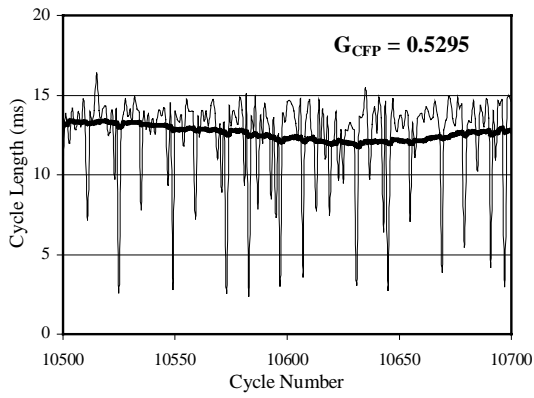

Fig. 8. High level of delay sensitive load

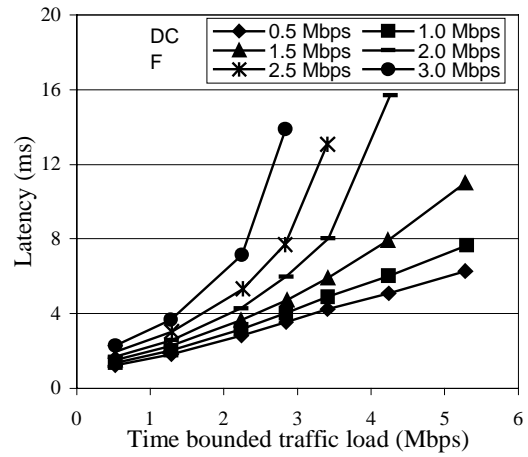

Fig. 9. Latency behaviour of the DCF

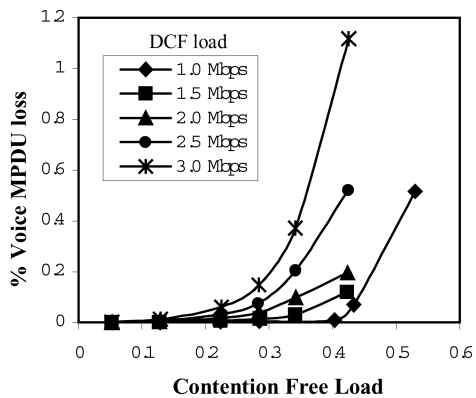

Fig. 10. Behaviour of voice MPDU loss

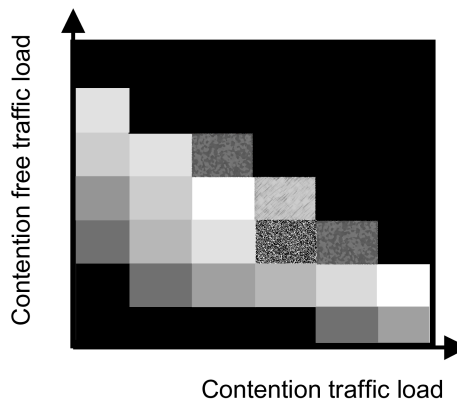

Fig. 11. Voice MPDU loss intensity

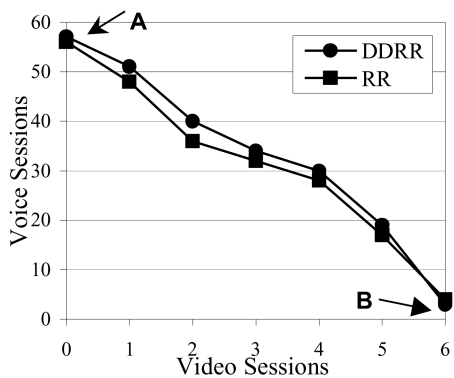

Fig. 12. Number of simultaneous voice and video

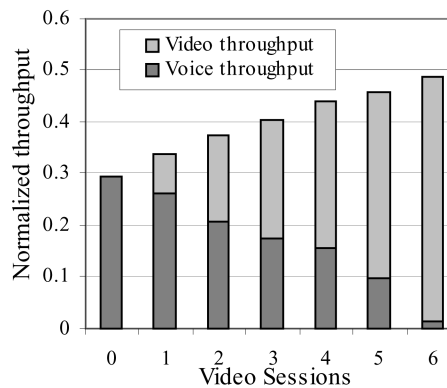

Fig. 13. Normalized CF throughput

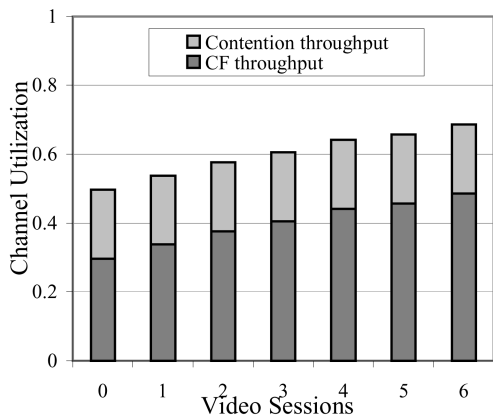

Fig. 14. Overall channel throughput

## Appendix: DRR Algorithm

### At the start of each CF cycle:

Mark all stations active

**WHILE** ((SchedulingList not empty) **AND**  
(CF remaining time < CF\_MAX\_Duration) **AND**  
(**NOT** all stations inactive))

$DC_i' = DC_i' + Q_i$ ;

Set MoreData;

**WHILE** (( $DC_i > 0$ ) **AND** (MoreData))

Poll terminal  $i$ ;

Receive packet  $p$ ;

$DC_i' = DC_i' - \text{length of packet } p$ ;

Read MoreData from  $p$ ;

**END-WHILE**

**IF** (**NOT** MoreData)

$DC_i = 0$ ;

Make the  $i^{\text{th}}$  station inactive;

**END-IF**

$i = i + 1$ ;

**END-WHILE**